

STAND MIXER

KASTMXBABKA & KASTMXBAWTA

SAFETY & WARNINGS

Before using the electrical appliance, the following basic precautions should always be followed including the following:

- Read all instructions before first usage and retain this user guide for future reference.
- Before use, check that the voltage of your wall outlet corresponds to the one on the rating plate which is on the bottom of the appliance.
- Do not operate the appliance with a damaged cord or after malfunction or has been damaged in any manner. Cease use immediately and contact **help.Kogan.com** for support.
- Do not let cord hang over the edge of a table, counter or hot surface.
- Do not immerse the cord or the body of mixer into water as this would give rise to electric shock.
- If the supply cord is damaged, cease use immediately and contact **help.Kogan.com** for support.
- Close supervision is necessary when your appliance is being used near children.
- Do not place an appliance on or near a hot gas or on a heated oven.
- Never eject beaters or dough hooks when the appliance is in operation.
- Do not leave mixer unattended while it is operating.
- Unplug from outlet while not in use, before putting on or taking off parts and before cleaning.
- The use of attachments not recommended or sold by Kogan.com may cause fire, electric shock or injury
- Remove beaters from mixer before washing.
- Always check that the control is OFF before plugging cord into wall outlet. To disconnect, turn the control to OFF, then remove plug from wall outlet.
- Avoid contacting moving parts.
- Keep hands, clothing, as well as spatulas and other utensils away from beaters during operation to reduce the risk of injury to persons and/or damage to the mixer.
- Always disconnect the appliance from the supply if it is left unattended and before assembling, disassembling or cleaning.
- This appliance shall not be used by children. Keep the appliance and its cord out of reach of children.
- Switch off the appliance before changing accessories or approaching parts which move in use.

- This appliance is intended to be used in household and similar applications such as:
 - Staff kitchen areas in shops, offices and other working environments;
 - Farm houses;
 - By clients in hotels, motels and other residential type environments;
 - Bed and breakfast type environments.
- Save these instructions.

OVERVIEW

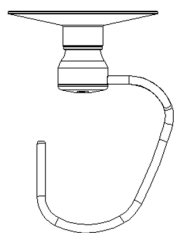
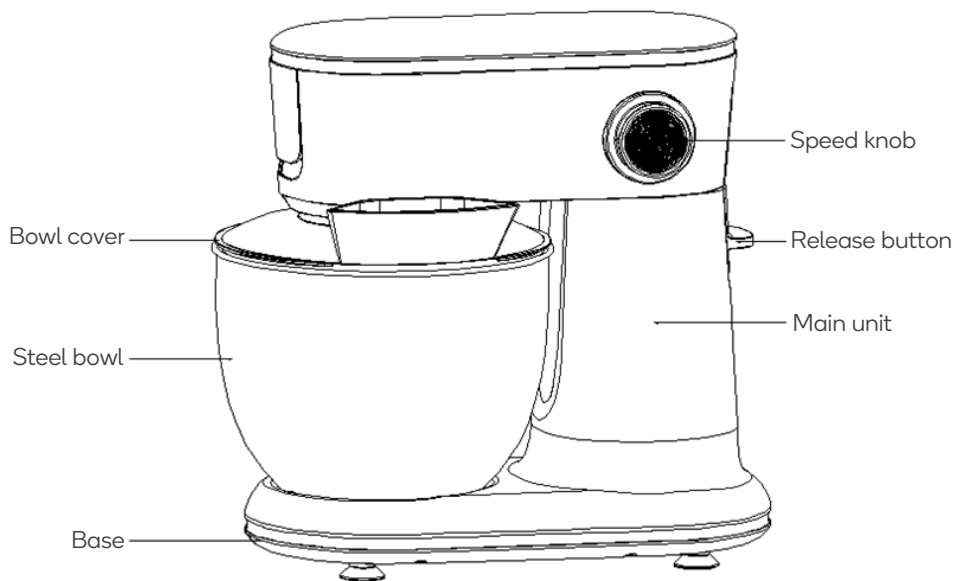

Dough hook

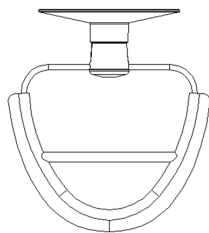

Beater

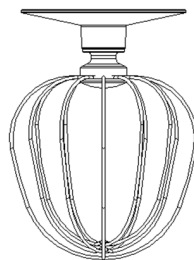

Whisk

BEFORE FIRST USE

Before assembling the mixer, be sure the power cord is unplugged from the power outlet and the speed selector is in the 0 position.

1. Press the release button, the head of mixer will automatically release and lock into tile position.
2. Select the desired attachments, depending on the mixing task to be performed:
 - Beater for mixing and beating eggs
 - Dough hook for kneading,
 - Whisk for beating and frothing egg white.
3. Insert the Beater/ dough hook/whisk directly, until it locks into position.

Note:

Ensure the attachment is fully inserted into the socket, otherwise your mixing results may be affected.

4. Place bowl in position. First place the bowl on the base, then turn the bowl clockwise until it locks into position.
5. To lower the head and attachment into the bowl, holding the head with the one hand, slowly ease the head down. A click sound will be heard when the head is properly in place.

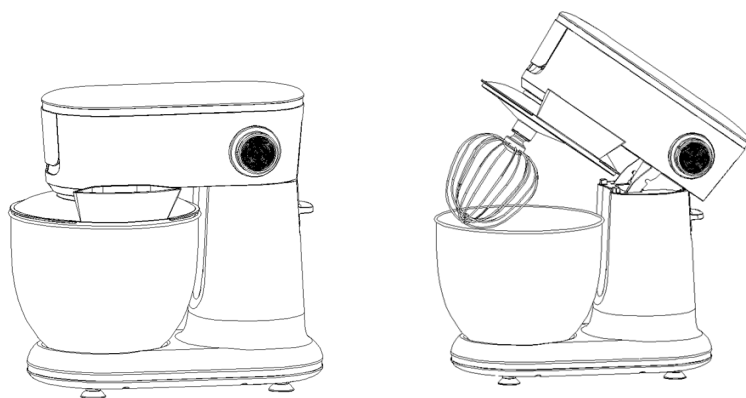

OPERATION

1. Ensure that the speed selector is at the 0 position, then plug in the power cord.
2. Turn the speed selector to your desired setting;
 - Low-speed (1-3 gear) is used with the dough hook
 - Medium speed (4-6 gear) is used with the beater
 - High speed gear is used with the whisk.

WARNING: Do not stick knives, metal spoons, forks or other utensils into the bowl while the mixer is moving.

3. The maximum operating time should not exceed 6 minutes and a minimum 20 minutes rest time must be maintained between two consecutive cycles.
Note: When kneading yeast dough, suggest the speed selector first use a low speed and then use high speed to achieve the best results.

Note:

During kneading, some flour may adhere on the inside of the bowl. Ensure you remove the bowl cover and scrape the flour from the sides of the bowl using a spatula.

4. When mixing is complete, turn the speed selector to 0 position, unplug the cord from power outlet.
5. Hold down the release button, the head of the mixer will automatically lift and lock into the tilt position.

WARNING: Before lifting the mixer's head, make sure the attachment is positioned correctly on both sides of the head. This prevents any interference with the mixing bowl.

If the attachment is resting at the front of the head, use the speed selector to rotate it for a few seconds. Then, turn off the speed selector to align the attachment properly on both sides of the mixer's head.

Before lifting the mixer's head, make sure the attachment is positioned correctly on both sides of the head. This prevents any interference with the mixing bowl.

6. If necessary, you can scrape the excess food particles from the beaters or dough hooks using a plastic spatula.
7. To remove attachments, gently pull them away from the mixer's head.

WARNING: The speed selector must be at 0 position and the power outlet must be unplugged before pulling out the attachments.

Attachment	Ingredients	Weight	Instructions
Beater	Flour	150g	Set to low for 30s, then set it to the highest level of work for 3 minutes
	Sugar	150g	
	Butter	150g	
	Eggs	3pieces	
	Baking Soda	3g	
Dough hook	Flour	500g	Set to low for 30s, then set it to the 3 level of work for 4 minutes
	Water	300g	
Whisk	Eggs	4pieces	Set to highest level of work for 2 minutes

CLEANING & CARE

Unplug the appliance and wait for it to completely cool down before cleaning.

Caution: the mixer cannot be immersed in water or other liquid.

- Wipe the outside surface of the head and base with a damp cloth and dry with a soft dry cloth.
- Wipe any excess food particles from the power cord.
- Immerse the bowl and attachments in warm soapy water, then rinse under running water and wipe dry.
- Do not place beater and dough hook in a dishwasher.

Tips:

- Refrigerated ingredients, such as butter and eggs, should be at room temperature before mixing begins. Set these ingredients out ahead of time.
- To eliminate the possibility of shells or spoiled eggs in your recipe, break eggs into a separate container first before adding to the mixture.
- Do not over-beat. Be careful that you only mix/blend mixtures until recommended in your recipe. Fold into dry ingredients only until just combined. Always use the low speed.
- Climatic conditions. Seasonal temperature changes, temperature of ingredients and their texture variation from area to area all play a part in the required mixing time and the results achieved.

Always start mixing at lowest speed. When ingredients combine to form a smooth paste, increase to the recommended speed gradually in the recipe sheet.



This marking indicates that this appliance should not be disposed with other household wastes. To prevent possible harm to the environment or human health from uncontrolled waste disposal, recycle it responsibly to promote the sustainable reuse of material resources.



Need more information?

We hope that this user guide has given you the assistance needed for a simple set-up.

For the most up-to-date guide for your product, as well as any additional assistance you may require, head online to **help.kogan.com**

kogan.com