

Table of Contents

Segway ES Series - 1

Mi Electric Scooter - 15

User Manual

by **SEGWAY**

The manufacturer reserves the right to make changes to the product, release firmware updates, and update this manual at any time. Visit www.segway.com or check the App to download the latest user materials. You must install the App, activate your KickScooter, and obtain the latest updates and safety instructions.

www.segway.com

25612-00001 aa

ninebot[®] KickScooter

ANSI/CAN/UL-2272 certified; ANSI/UL 2271 certified
Visite www.segway.com para baixar o manual do usuário.
Original Instructions

Contents

1 Riding Safety	02
2 Packing List	04
3 Diagram	05
4 Assembling Your KickScooter	06
5 Installing a Second Battery Pack	07
6 First Ride	08
7 Charging	09
8 Learning to Ride	09
9 Warnings	11
10 Folding and Carrying	15
11 Maintenance	16
12 Specifications	17
13 Certifications	18
14 Trademark and Legal Statement	20
15 Contact	21

Thanks for choosing the Ninebot KickScooter ES series!

Thanks for choosing the Ninebot KickScooter (hereinafter referred to as KickScooter)!

Your KickScooter is a fashionable transportation device with mobile app, allowing you to connect with other riders.

Enjoy your ride and connect with riders world wide!



▲ WARNING!

Always use both electric brake and foot brake for emergency stopping. Otherwise you risk falls and/or collisions from not achieving the max. braking capability.

1 Riding Safety

1. The KickScooter is a recreational transporter. Before mastering riding skills, you need to practice. Neither Ninebot Inc. (means Ninebot (Beijing) Tech Co., Ltd. and its subsidiaries and affiliates) nor Segway Inc. is responsible for any injuries or damage caused by a rider's inexperience or failure to follow the instructions in this document.
2. Please understand that you can reduce the risk by following all the instructions and warnings in this manual, but you cannot eliminate all the risks. Remember that whenever you ride the KickScooter you risk injury from loss of control, collisions, and falls. When entering into public spaces always comply with the local laws and regulations. As with other vehicles, faster speeds require longer braking distance. Sudden braking on low traction surfaces could lead to wheel slip, or falls. Be cautious and always keep a safe distance between you and other people or vehicles when riding. Be alert and slow down when entering unfamiliar areas.
3. Always wear a helmet when riding. Use an approved bicycle or skateboard helmet that fits properly with the chin strap in place, and provides protection for the back of your head.
4. Do not attempt your first ride in any area where you might encounter children, pedestrians, pets, vehicles, bicycles, or other obstacles and potential hazards.
5. Respect pedestrians by always yielding the right of way. Pass on the left whenever possible. When approaching a pedestrian from the front, stay to the right and slow down. Avoid startling pedestrians. When approaching from behind, announce yourself and slow down to walking speed when passing. Please obey local traffic laws and regulations if situation is different.
6. In places without laws comply with the safety guidelines outlined in this manual. Neither Ninebot Inc. nor Segway Inc. is responsible for any property damage, personal injury/death, accidents, or legal disputes caused by violations of the safety instructions.
7. Do not allow anyone to ride your KickScooter on his/her own unless they have carefully read this manual and followed the New Rider Tutorial in the App. The safety of new riders is your responsibility. Assist new riders until they are comfortable with the basic operation of the KickScooter. Make sure each new rider wears a helmet and other protective gear.
8. Before each ride check for loose fasteners and damaged components. If the KickScooter makes abnormal sounds or signals an alarm, immediately stop riding. Diagnose your KickScooter via the Ninebot by Segway App and call your dealer/distributor for service.
9. Be alert! Scan both far ahead and in front of your KickScooter — your eyes are your best tool for safely avoiding obstacles and low traction surfaces (including, but not limited to, wet ground, loose sand, loose gravel, and ice).
10. To reduce risk of injury, you must read and follow all "CAUTION" and "WARNING" notices in this document. Do not ride at an unsafe

speed. Under no circumstance should you ride on roads with motor vehicles. The manufacturer recommends riders be 14+ years old. Always follow these safety instructions:

- A. People who should not ride the KickScooter include:
 - i. Anyone under the influence of alcohol or drugs.
 - ii. Anyone who suffers from disease that puts them at risk if they engage in strenuous physical activity.
 - iii. Anyone who has problems with balance or with motor skills that would interfere with their ability to maintain balance.
 - iv. Anyone whose weight is outside the stated limits (see Specifications).
 - v. Pregnant women.
 - B. Riders under the age of 18 years old should ride under adult supervision.
 - C. Comply with local laws and regulations when riding this product. Do not ride where prohibited by local laws.
 - D. To ride safely, you must be able to clearly see what is in front of you and you must be clearly visible to others.
 - E. Do not ride in the snow, in the rain, or on roads which are wet, muddy, icy, or that are slippery for any reason. Do not ride over obstacles (sand, loose gravel, or sticks). Doing so could result in a loss of balance or traction and could cause a fall.
11. Do not attempt to charge your KickScooter if it, the charger, or the power outlet is wet.
 12. As with any electronic device, use a surge protector when charging to help protect your KickScooter from damage due to power surges and voltage spikes. Only use the Segway supplied charger. Do not use a charger from any other different product models.
 13. Use only Ninebot or Segway approved parts and accessories. Do not modify your KickScooter. Modifications to your KickScooter could interfere with the operation of the KickScooter, could result in serious injury and/or damage, and could void the Limited Warranty.

2 Packing List

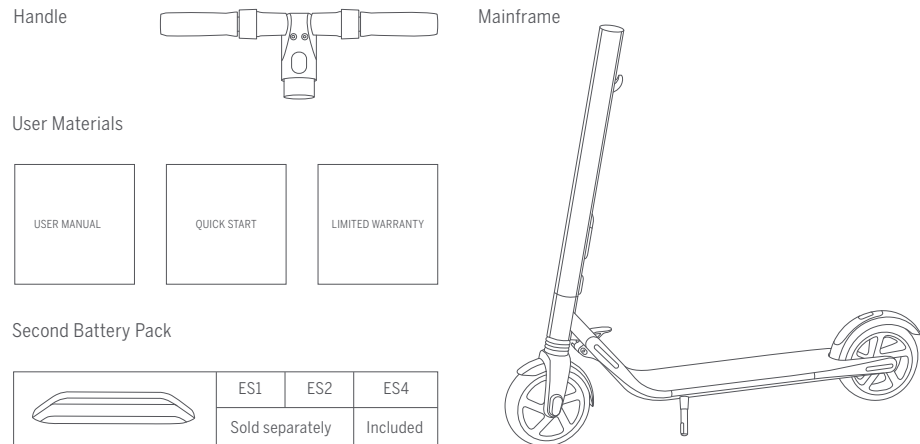

Accessories

M4 Flathead Screw x 5
(one extra)



M4 Hex Wrench



Battery Charger

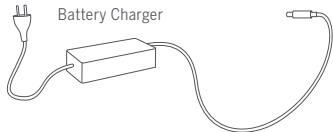

When unboxing your KickScooter, please verify that the above items are included in the package. If you are missing any components, please contact your dealer/distributor or nearest service center (see contacts in the user manual). After verifying that all components are present and in good condition, you can assemble your new KickScooter.

Please retain the box and packaging materials in case you need to ship your KickScooter in the future.

Remember to power off your KickScooter and unplug the charge cable before assembling, mounting accessories, or cleaning the mainframe.

3 Diagram

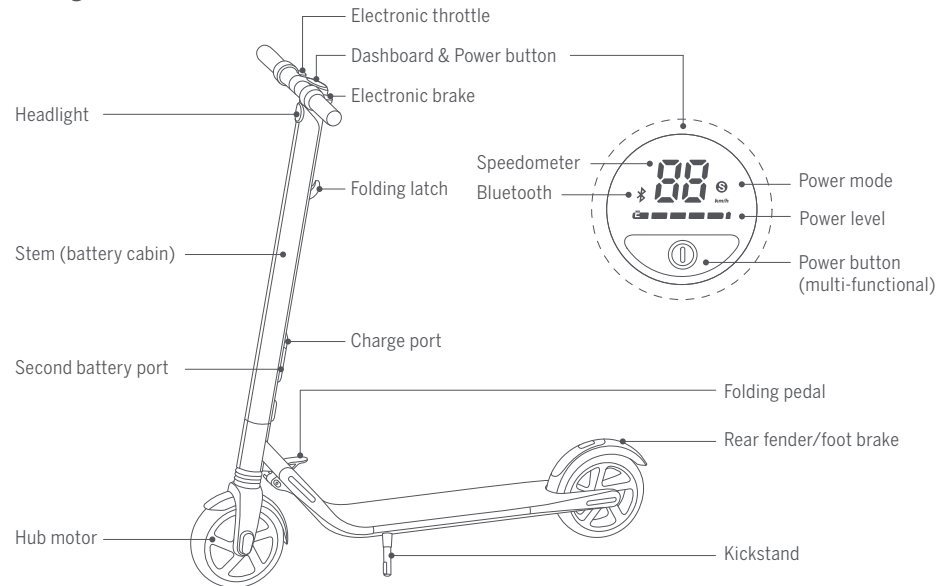

Dashboard & Power Button

Speedometer: Indicates the current speed. Also displays error codes when faults are detected.

Power level: Indicates the remaining battery level with 5 bars. Each bar equates to approximately 20% power level.

Power mode (double click the power button to switch the mode):

—Red "S" icon: Sport mode (maximum power/speed and reduced range).

—White "S" icon: Standard mode (moderate power/speed and range).

—No "S" icon: Speed limit mode (minimum power/speed and increased range).

Bluetooth: A blinking Bluetooth icon indicates that the vehicle is ready to connect. A solid Bluetooth icon indicates that the vehicle is connected to a mobile device.

Power button: Short press to power on. Long press to power off. When powered on, single click to turn on/off the headlight. Double-click to change power mode.

4 Assembling Your KickScooter

1. Unfold the stem and push it until you hear a click. Then unfold the kickstand to support the scooter.

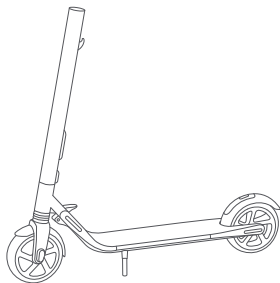

3. Install four screws (two on each side) with the included hex wrench.

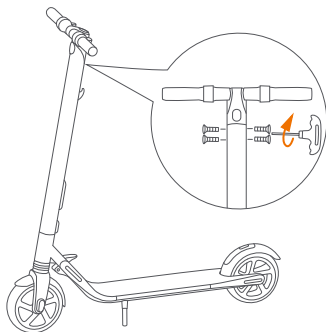

2. Firmly connect the wires inside the handle and the stem. Slide the handle onto the stem. Be aware of the correct orientation.

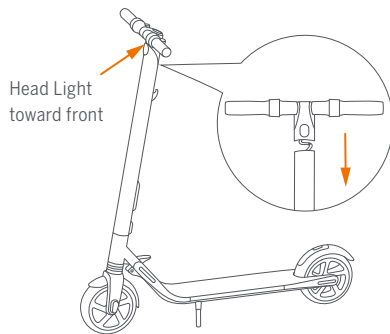

4. Verify that your KickScooter powers on and off.

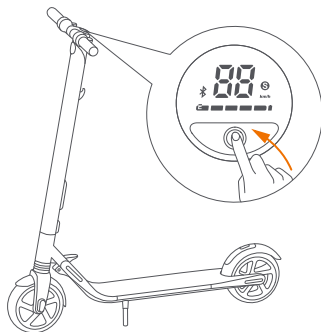

5 Installing a Second Battery Pack

Follow these steps when installing a second battery pack:

1. Remove the three screws on the stem, as shown. Then remove the cover near the charge port.

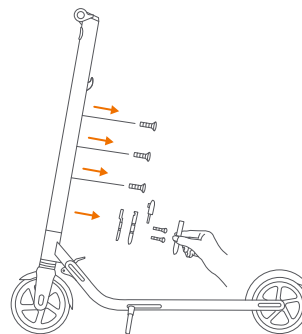

3. Install the battery pack onto the support bracket and tighten the screws securely.

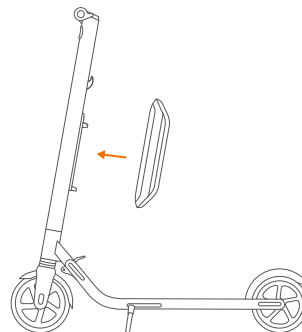

2. Install the support bracket and fasten securely with three screws, as shown.

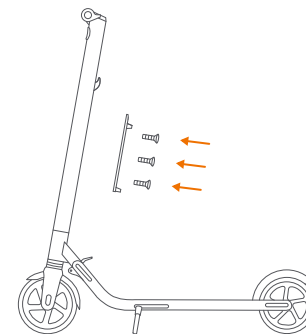

4. Verify that your KickScooter powers on and off.

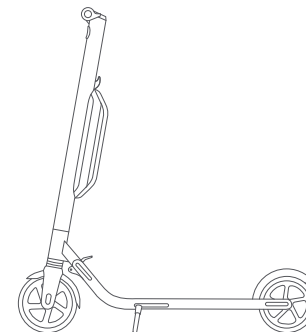

6 First Ride

⚠ There are safety risks when learning to ride the KickScooter. You must read the Safety Instructions via the App before your first ride.

For your safety, your new KickScooter is not activated and will beep occasionally after Power ON.

Until activated, the KickScooter maintains a very low riding speed, and can not be ridden with full function. Install the App on your mobile device (with Bluetooth 4.0 or above), connect to the KickScooter with Bluetooth, and follow the App instructions to activate your KickScooter and enjoy the full performance.

Scan the QR code to download the App (iOS 8.0 or above, Android™ 4.3 or above).



- 1 Install the App and register/login.

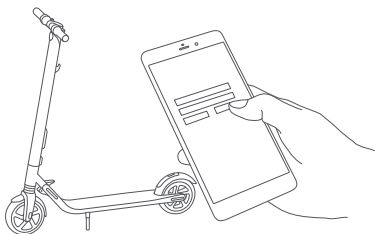

- 3 Click "Vehicle" → "Search device" to connect to your KickScooter.
The KickScooter will beep when the connection is successful. The Bluetooth icon will stop blinking and remain illuminated.

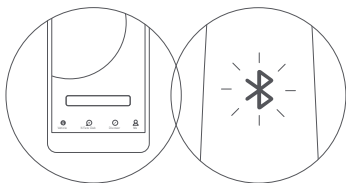

- 4 Follow the App instructions to activate the KickScooter and learn how to ride safely.
You can now start to use your KickScooter, check the status with App, and interact with other users. Have fun!

- 2 Power on the KickScooter. A blinking Bluetooth icon indicates the KickScooter is waiting for a connection.

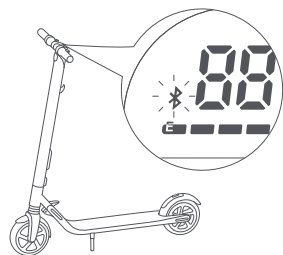

7 Charging

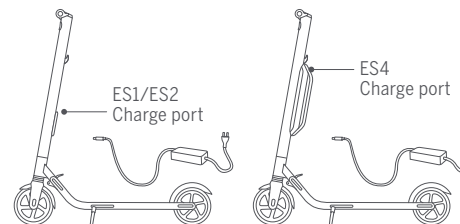

Charging step tips



Open the charge port cover.

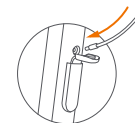

Insert the charge plug.

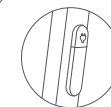

Close the charge port cover when finished.

⚠ WARNING

Do not connect the charger if the charge port or charge cable is wet.

Your KickScooter is fully charged when the LED on the charger changes from red (charging) to green (trickle charge). Close the charge port cover when not charging.

8 Learning to Ride



Wear an approved helmet and other protective gear to minimize any possible injury.

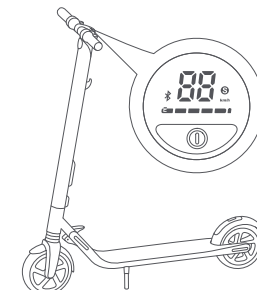

1. Power on the scooter and check the indicator lamp power level. Charge the scooter if the battery level is low.

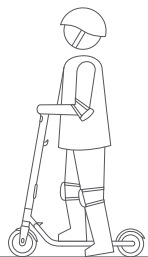

2. Stand on the footrest with one foot and push off with your foot to start gliding.

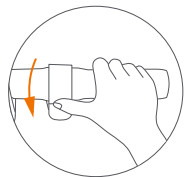

3. Put your other foot on the footrest to keep both feet stable. Press the throttle on right hand to speed up when you are balanced.

Note. For your safety, the motor will not engage until the scooter reaches 1.8 mph (3 km/h).

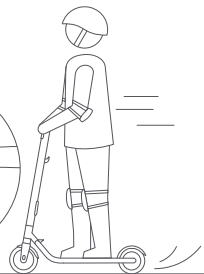
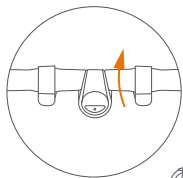

4. Slow down by releasing the throttle; stir the brake handle thumb shifter quickly and stamp the fender with foot at the same time to trigger mechanical braking in order to make a sharp brake.

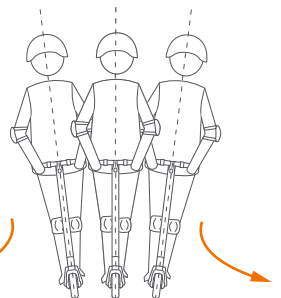

5. To turn, shift your body weight and turn the handle slightly.

⚠ WARNING

When braking rapidly you risk serious injury due to loss of traction and falls. Maintain a moderate speed and look out for potential hazards.

9 Warnings

⚠ WARNING

Failure to follow these instructions could lead to serious injury.



⚠ DO NOT ride the scooter in the rain.

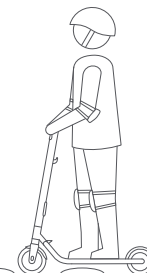

⚠ DO NOT ride over speed bumps, thresholds, or other bumps at HIGH SPEED.

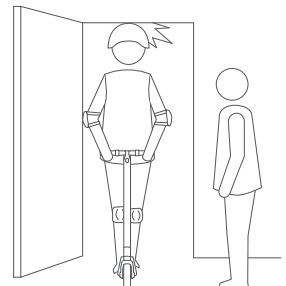

⚠ Watch your head when passing through doorways.

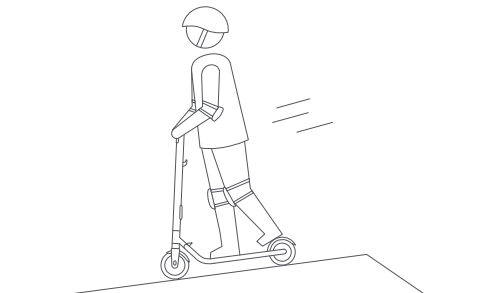

⚠ Watch your speed when traveling downhill. Use both brakes together when traveling at high speed.

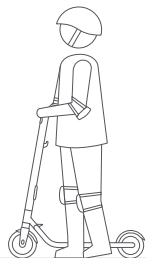
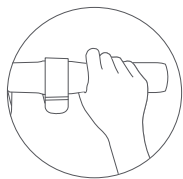

! DO NOT press the throttle when walking with the scooter.

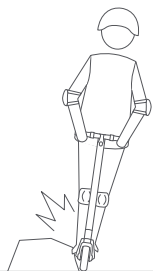

! Avoid contacting obstacles with the tire/wheel.

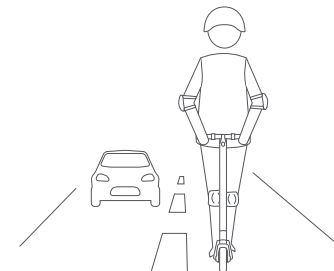

! DO NOT ride on public roads, motorways, or highways.

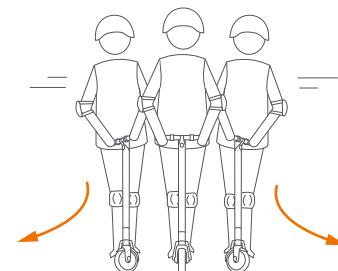

! DO NOT rotate the handle violently while driving at high speed.

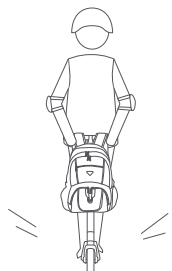

! DO NOT carry heavy objects on the handlebar.

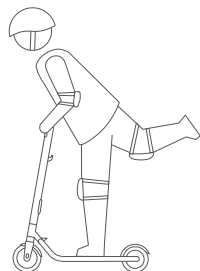

! DO NOT ride the scooter with only one foot.



! DO NOT ride through puddles or other bodies of water deeper than 1 inch (2 cm).

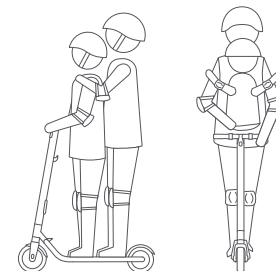

! The KickScooter is for one rider only. Do not ride double or carry any passengers. Do not carry a child.

10 Folding and Carrying

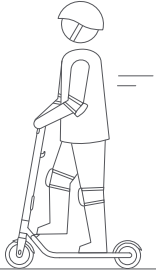

⚠ DO NOT step on the folding pedal while riding.

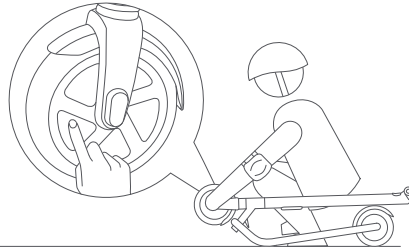

⚠ DO NOT touch the hub motor after riding because it can get hot.

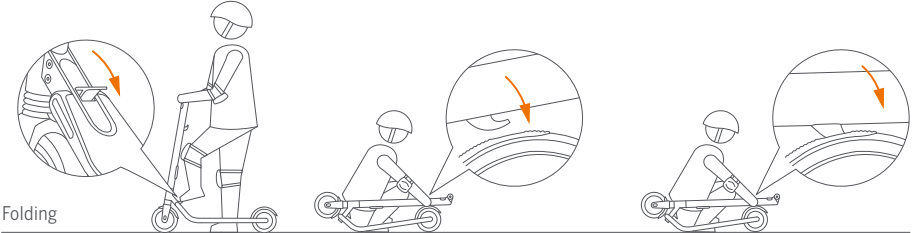

Folding

Step on the folding pedal while pushing the handlebar forward slightly. Then fold the handlebar down until it locks into the rear fender.



⚠ DO NOT take your hands off the handlebar while riding. Do not ride with one hand only.

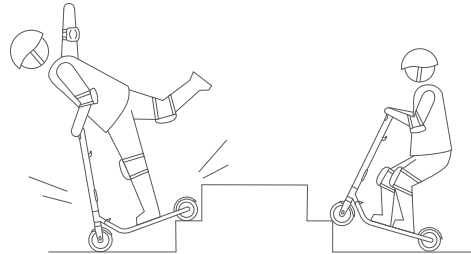

⚠ DO NOT ride up and down stairs or jump over obstacles.

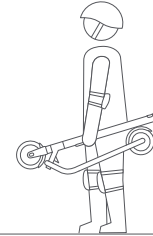

Carrying

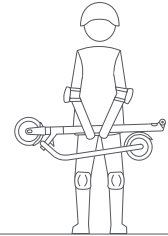

When your KickScooter is folded up, simply lift it by the stem to carry.

⚠ WARNING
Always keep both hands on the handlebar or you risk serious injury due to loss of balance and falls.

11 Maintenance

Cleaning and Storage

Use a soft, wet cloth to wipe the mainframe clean. Hard to remove dirt can be scrubbed with a toothbrush and toothpaste, then cleaned with a soft, wet cloth. Scratches on plastic parts can be polished with fine grit abrasive paper.

NOTE

Do not wash your KickScooter with alcohol, gasoline, acetone, or other corrosive/volatile solvents. These substances may damage the appearance and internal structure of your KickScooter. Do not wash your KickScooter with a power washer or hose.

WARNING

Make sure the KickScooter is powered OFF, the charging cable is unplugged, and the rubber cap on the charge port is tightly sealed before cleaning; otherwise you may damage the electronic components.

Store your KickScooter in a cool, dry place. Do not store it outdoors for extended periods of time. Exposure to sunlight and temperature extremes (both hot and cold) will accelerate the aging process of the plastic components and may reduce battery life.

Battery Pack Maintenance

Do not store or charge the battery at temperatures outside the stated limits (see Specifications). Do not puncture the battery. Refer to your local laws and regulations regarding battery recycling and/or disposal.

A well maintained battery can perform well even after many miles of riding. Charge the battery after each ride and avoid draining the battery completely. When used at room temperature (70°F [22°C]) the battery range and performance is at its best; whereas using it at temperatures below 32°F (0°C) can decrease range and performance. Typically, at -4°F (-20°C) range can be half that of the same battery at 70°F (22°C). Battery range will recover when temperature rises. More details are available in the App.

NOTE

Typically, a fully charged battery should retain charge for 120-180 days in Standby Mode. A low-power battery should retain charge for 30-60 days in Standby Mode. Remember to charge the battery after each use. Completely draining the battery may cause permanent damage to the battery. Electronics inside the battery record the charge-discharge condition of the battery; damage caused by over-discharge or under-discharge will not be covered by the Limited Warranty.

WARNING

Do not attempt to disassemble the battery. Risk of fire. No user serviceable parts.

WARNING

Do not ride when the ambient temperature is outside the machine operation temperature (see Specifications) because low/high temperature will limit the maximum power/torque. Doing so could cause personal injury or property damage due to slips or falls.

12 Specifications

	Item	ES1	ES2	ES4
Dimensions	Unfold: Length x Width x Height	40x17x45 in (102x43x113 cm)		
	Fold: Length x Width x Height	45x17x16 in (113x43x40 cm)		
Weight	Net	24.9 lbs (11.3 kg)	27.6 lbs (12.5 kg)	30.9 lbs (14.0 kg)
	Payload	55–220 lbs (25–100 kg)		
Rider	Recommended Age	14+ years		
	Required Height	3' 11"–6' 6" (120–200 cm)		
	Max. Speed	12.4 mph (20 km/h)	15.5 mph (25 km/h)	18.6 mph (30 km/h)
Machine Parameters	Typical Range ^[1]	15.5 miles (25 km)	15.5 miles (25 km)	28.0 miles (45 km)
	Max. Slope	10%	10%	15%
	Traversable Terrain	asphalt/flat pavement; obstacles < 0.4 in (1 cm); gaps < 1.2 in (3 cm)		
	Operating Temperature	14–104°F (-10–40°C)		
	Storage Temperature	-4–122°F (-20–50°C)		
	IP Rating	IP54		
	Battery	Nominal Voltage	36 VDC	
Max. Charging Voltage		42 VDC		
Charging Temperature		32–104°F (0–40°C)		
Nominal Capacity		187 Wh	187 Wh	374 Wh
Battery Management System		Over-heating, short circuit, over-current and over-charge protection		
Number Of Batteries ^[2]		1	1	2
Motor	Nominal Power	250 W	300 W	300 W
	Max. Power	500 W	700 W	800 W
Charger	Output Power	71 W		
	Input Voltage	100-240 VAC		
	Output Voltage	42 VDC		
	Output Current	1.7 A		
	Duration of Charging	3.5 h	3.5 h	7 h
Features	Shock Absorber	front	front & rear	
	Brake Light	reflector	LED rear light	
	Atmosphere Light	N/A	Customizable colour	
	Riding Modes	Speed limit mode, Standard mode and Sport mode		

[1] Typical Range: tested while riding under full power, 165 lbs (75 kg) load, 77°F (25°C), 60% of max. speed on average on pavement.

[2] All KickScooter models could install the second battery. Some of the parameters would change in this case.

13 Certifications

This product has been tested to and passed ANSI/CAN/UL-2272.

The battery complies with UN/DOT 38.3.

The second battery pack complies with ANSI/UL 2271 and UN/DOT 38.3.

Federal Communications Commission (FCC) Compliance Statement for USA

This device complies with part 15 of the FCC rules. Operation is subject to the following two conditions: (1) This device may not cause harmful interference, and (2) this device must accept any interference received, including interference that may cause undesired operation.

NOTE

This equipment has been tested and found to comply with the limits for a Class B digital device, pursuant to part 15 of the FCC Rules. These limits are designed to provide reasonable protection against harmful interference in a residential installation. This equipment generates, uses and can radiate radio frequency energy and, if not installed and used in accordance with the instructions, may cause harmful interference to radio communications. However, there is no guarantee that interference will not occur in a particular installation. If this equipment does cause harmful interference to radio or television reception, which can be determined by turning the equipment off and on, the user is encouraged to try to correct the interference by one or more of the following measures:

- Reorient or relocate the receiving antenna.
- Increase the separation between the equipment and receiver.
- Connect the equipment into an outlet on a circuit different from that to which the receiver is connected.
- Consult the dealer or an experienced radio/TV technician for help.

This equipment complies with FCC radiation exposure limits set forth for an uncontrolled environment.

Industry Canada (IC) Compliance Statement for Canada

This device complies with Industry Canada license-exempt RSS standard (s). Operation is subject to the following two conditions: (1) this device may not cause interference, and (2) this device must accept any interference, including interference that may cause undesired operation of the device.

CAN ICES-3 (B)/NMB-3(B)

Neither Segway Inc. nor Ninebot is responsible for any changes or modifications not expressly approved by Segway Inc. or Ninebot. Such modifications could void the user's authority to operate the equipment.

For model: ES1/ES2/ES4

FCC ID: 2ALS8-NT9527

IC: 22636-NT9527

European Union Compliance Statement

Battery recycling information for the European Union



Batteries or packaging for batteries are labeled in accordance with European Directive 2006/66/EC concerning batteries and accumulators and waste batteries and accumulators. The Directive determines the framework for the return and recycling of used batteries and accumulators as applicable throughout the European Union. This label is applied to various batteries to indicate that the battery is not to be thrown away, but rather reclaimed upon end of life per this Directive.

In accordance with the European Directive 2006/66/EC, batteries and accumulators are labeled to indicate that they are to be collected separately and recycled at end of life. The label on the battery may also include a chemical symbol for the metal concerned in the battery (Pb for lead, Hg for mercury, and Cd for cadmium). Users of batteries and accumulators must not dispose of batteries and accumulators as unsorted municipal waste, but use the collection framework available to customers for the return, recycling, and treatment of batteries and accumulators. Customer participation is important to minimize any potential effects of batteries and accumulators on the environment and human health due to the potential presence of hazardous substances.

Restriction of Hazardous Substances Directive (RoHS)

Ninebot products sold in the European Union, on or after 3 January 2013 meet the requirements of Directive 2011/65/EU on the restriction of the use of certain hazardous substances in electrical and electronic equipment ("RoHS recast" or "RoHS 2").

Radio and Telecommunications Terminal Equipment Directive



Segway Europe B.V.

EU Contact Address for regulatory topics only: Hogehilweg 8, 1101CC Amsterdam, The Netherlands.

Hereby, Ninebot (Changzhou) Tech Co., Ltd, declares that the wireless equipment listed in this section are in compliance with the essential requirements and other relevant provisions of Directive 2014/53/EU.

14 Trademark and Legal Statement

Ninebot and the shape icon are trademarks of Ninebot (Tianjin) Tech. Co., Ltd; Segway is the registered trademark of Segway Inc.; Ninebot by Segway is a trademark of Segway Inc.; Android, Google Play are trademarks of Google Inc. App Store is a service mark of Apple Inc. The respective owners reserve the rights of their trademarks referred to in this manual.

The KickScooter is covered by relevant patents. For patent information go to <http://www.segway.com>.

We have attempted to include descriptions and instructions for all the functions of the KickScooter at the time of printing. However, your KickScooter may differ slightly from the one shown in this document. Visit the Apple App Store (iOS) or the Google Play Store (Android) to download and install the App.

Please note that there are multiple Segway and Ninebot by Segway models with different functions, and some of the functions mentioned herein may not be applicable to your unit. The manufacturer reserves the right to change the design and functionality of the KickScooter product and documentation without prior notice.

© 2017 Ninebot (Beijing) Tech Co. Ltd. All rights reserved.

15 Contact

Contact us if you experience issues relating to riding, maintenance and safety, or errors/faults with your KickScooter.

Americas:

Segway Inc.

14 Technology Drive, Bedford, NH 03110, USA

Tel : 1-603-222-6000

Fax: 1-603-222-6001

Toll Free: 1-866-473-4929

E-mail Sales: customeroperation@segway.com

E-mail Service: technicalsupport@segway.com

Website: www.segway.com

Europe, Middle East and Africa:

Segway Europe B.V.

Hogehilweg 8, 1101CC Amsterdam, The Netherlands

Email service: service@segway.eu.com

Website: www.segway.com

Have your KickScooter serial number on hand when contacting Segway.

You can find your serial number on the underside of your KickScooter or in the App under More Settings -> Basic Information.

 **WARNING!**

Whenever you ride your vehicle you risk injury or death from loss of control, collisions, and falls. Be sure to read the User Manual and watch the Safety Video before riding.



The manufacturer reserves the right to make changes to the vehicle, release firmware updates, and update this manual at any time. Visit www.segway.com to download the latest user materials. You must install the App to follow the New Rider Tutorial, activate your vehicle, and obtain the latest updates and safety instructions.

25620-00001 aa

ninebot[®] KickScooter

QUICK START



Scan to download the App

Alternatively, go to the Google Play Store (Android) or the Apple App Store (iOS) and search for "Segway" or "Ninebot" to download and install the App. Be advised there is a minimum Android/iOS/Bluetooth version required. See User Manual for additional details.

First Ride



▲ There are safety risks when learning to ride the KickScooter. You must read the Safety Instructions via the App before your first ride.

For your safety, your new KickScooter is not activated and will beep occasionally after Power ON.

Until activated, the KickScooter maintains a very low riding speed, and can not be ridden with full function. Install the App on your mobile device (with Bluetooth 4.0 or above), connect to the KickScooter with Bluetooth, and follow the App instructions to activate your KickScooter and enjoy the full performance.

Scan the QR code to download the App (iOS 8.0 or above, Android™ 4.3 or above).

- 1 Install the App and register/login.

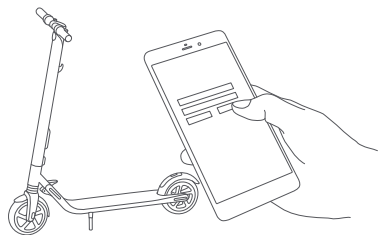

- 3 Click "Vehicle" → "Search device" to connect to your KickScooter.
The KickScooter will beep when the connection is successful. The Bluetooth icon will stop blinking and remain illuminated.

- 2 Power on the KickScooter. A blinking Bluetooth icon indicates the KickScooter is waiting for a connection.

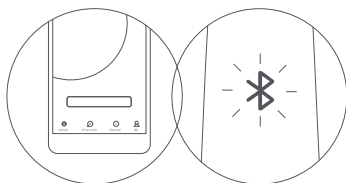
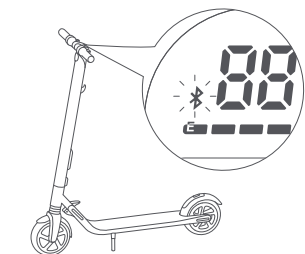

- 4 Follow the App instructions to activate the KickScooter and learn how to ride safely.
You can now start to use your KickScooter, check the status with App, and interact with other users. Have fun!

Learning to Ride



Wear an approved helmet and other protective gear to minimize any possible injury.

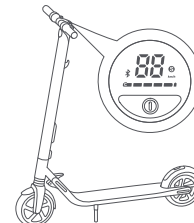

1. Power on the scooter and check the indicator lamp power level. Charge the scooter if the battery level is low.



2. Stand on the footrest with one foot and push off with your foot to start gliding.

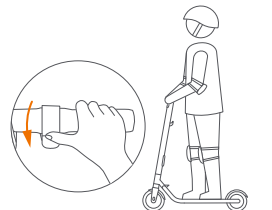

3. Put your other foot on the footrest to keep both feet stable. Press the throttle on right hand to speed up when you are balanced.

Note, For your safety, the motor will not engage until the scooter reaches 1.8 mph (3 km/h).

▲ WARNING

When braking rapidly you risk serious injury due to loss of traction and falls. Maintain a moderate speed and look out for potential hazards.

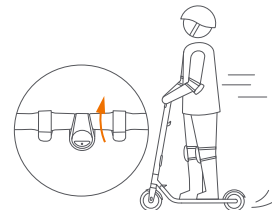

4. Slow down by releasing the throttle; stir the brake handle thumb shifter quickly and stamp the fender with foot at the same time to trigger mechanical braking in order to make a sharp brake.

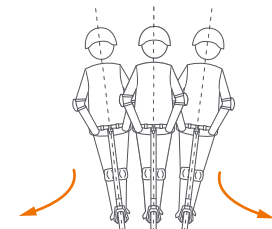

5. To turn, shift your body weight and turn the handle slightly.

Mi Electric Scooter User Manual

Actual functions may vary due to technical upgrades and firmware updates.
For latest functions and safety instructions, please go to Mi Community to exchange with other users.
Online support: www.mi.com/service

www.mi.com

V1.2



Thank you for purchasing

Thank you for purchasing Mi Electric Scooter. It is a sports and recreational vehicle with style.

Contents

1. Package Contents	02
2. Product Overview	03
3. Assembly and Set-Up	04
4. Charge Your Scooter	05
5. How To Ride	05
6. Safety Instructions	07
7. Folding and Carrying	12
8. Daily Care and Maintenance	13
9. Specifications	16
10. Trademark and Legal statement	17
11. Certifications	18
12. Quick Setup	20

1 Package Contents

Assembled Electric Scooter



User Manual



Legal Statement Quick Start Guide



Accessories

Extended Nozzle Adapter



Screw x 4



Hexagon Wrench



tire x 2



Charging Adapter



Carefully check package contents, if anything is missing or damaged, please contact local customer service for support.

2 Product Overview

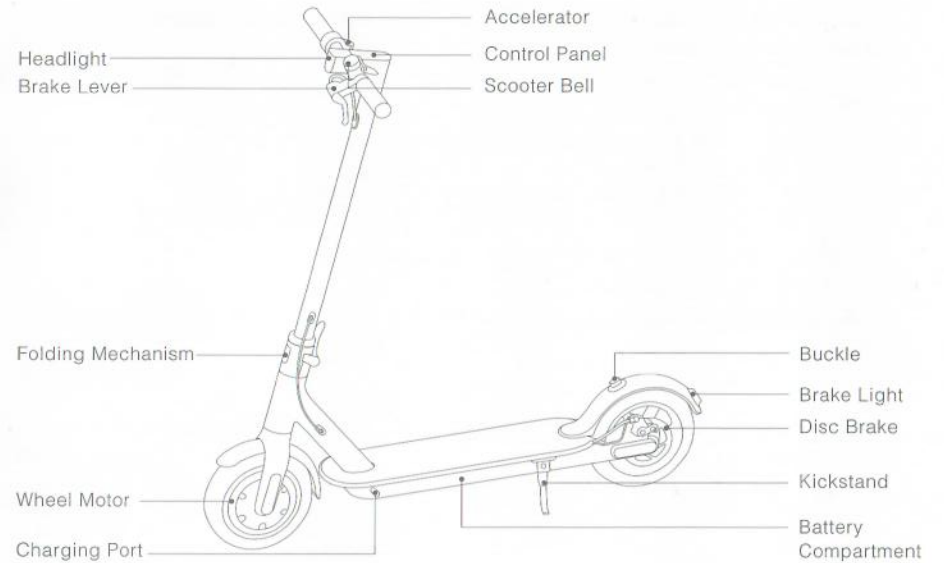

Control Panel



Battery level display

The power level is indicated by four power lights on the control panel. As power is consumed, the lights will change from solid to flashing, and finally turn off from up to down. When all four power lights are on, the battery level is between 100% - 86%; When three lights are solid and one is flashing, the battery level is between 85% - 71%, and so on. When the bottom power light flashes, it indicates low power. Please recharge soon for further use. After running out of power, all lights will turn off, and the scooter will coast until it comes to a complete stop.

Mode display

The bottom light either flashes white or green. The white light indicates regular mode, and green light indicates power-saving mode. (power-saving mode: max speed of 18km/h with smoother acceleration for beginners)

Power button

When the scooter is off, press the button to turn on the scooter; When the scooter is on, press and hold for 2 seconds to turn off the scooter. After turning on, press the button to turn on or off the headlight; And press twice to switch between modes.

3 Assembly and Set-Up

1. Fasten the handlebar stem on the headset, and put the kickstand down



2. Attach the handlebar to the stem



3. Tighten the screws onto both sides of the stem with the hexagon wrench



4. After the assembly, press the power button to check if it's working properly



4 Charge Your Scooter

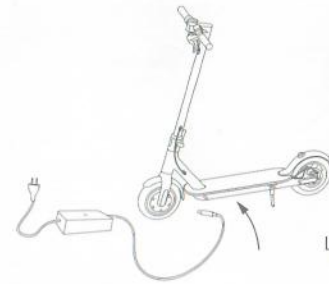

Lift up the rubber flap



Plug the power adapter into the charging port



When charging is completed, put back the rubber flap

5 How To Ride

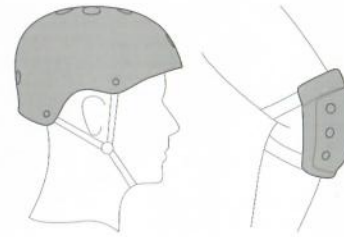

Wear helmets and knee pads in case of falls and injuries when you learn to ride the scooter



1. Turn on the scooter, and check the power indicator



2. Step on the deck with one foot, and slowly kicks off the other on the ground

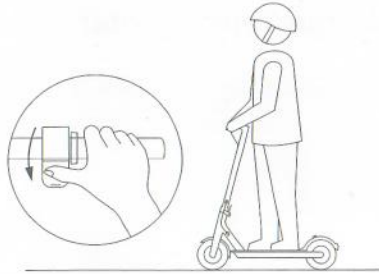

3. When the scooter starts to coast, put both feet on the deck and press the accelerator (the accelerator initiates once the coasting speed exceeds 5km/h)

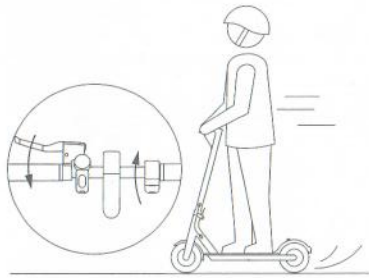

4. Release the accelerator and the kinetic energy recovery system (KERS) initiates automatically to brake slowly; And squeeze the brake lever for a sudden brake

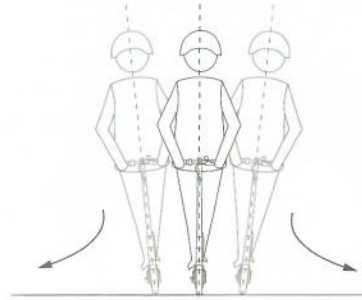

5. Tilt your body to the steering direction as you turn, and slowly turn the handlebar

6 Safety Instructions

Watch out for safety risks



 Do not ride in the rain

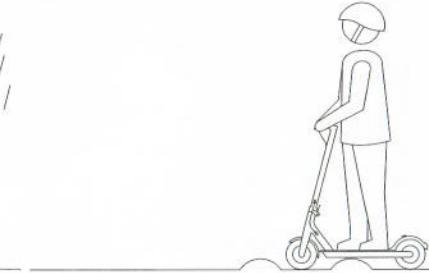

 Keep your speed between 5-10km/h when you ride through speed bumps, elevator door sills, bumpy roads or other uneven surfaces. Slightly bend your knee to better adjust mentioned surfaces

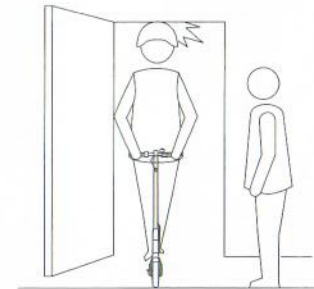

 Look out for doors, elevators and other overhead obstacles



 Do not accelerate when you go downhill

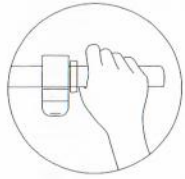

 Do not press the accelerator when you're walking alongside the scooter



 Always steer clear of obstacles

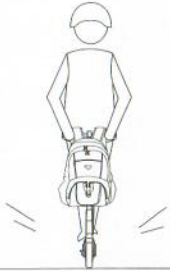



 Do not hang bags or other heavy stuff on the handlebar

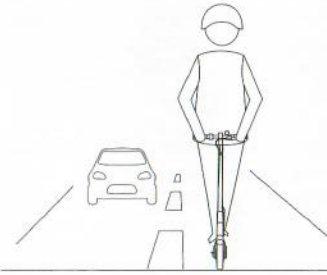

 Keep both feet on the deck all time.

Do not try following dangerous actions



 Do not ride in traffic lanes or residential areas where vehicles and pedestrians are both allowed



 Do not ride in a ponding that is higher than 2cm

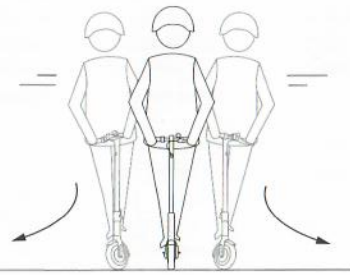

 Do not turn the handlebar violently during high-speed riding

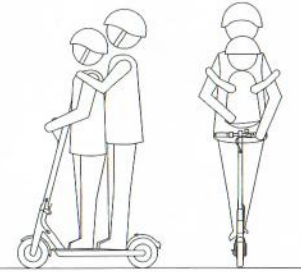

 Do not ride with anyone else, including children



❌ Do not keep your feet on the rear mudguard

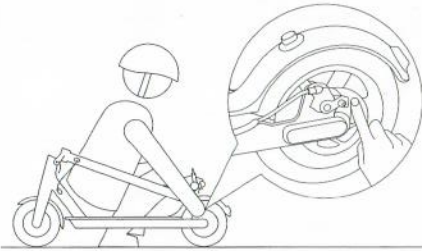

❌ Do not touch the disc brake



❌ Do not keep your hands away from handlebar

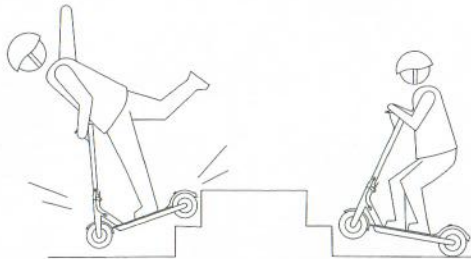

❌ Do not try riding up or down stairs, and jumping over obstacles

Safety Reminder

- This electric scooter is a leisure device. But once they're in a public area, they'll be seen as vehicles, subjecting to any risks faced by vehicles. For your safety, please follow instructions in the manual and traffic laws and regulations set forth by government and regulatory agencies. (Pour votre sécurité, veuillez suivre les instructions contenues dans le manuel et les lois sur la circulation et les règlements énoncés par les organismes gouvernementaux et réglementaires.)
- At the same time, you should understand that risks cannot be entirely avoided as others may violate traffic regulations and drive incautiously, and you're exposed to road accidents just as when you're walking or biking. The faster the scooter is, the longer it takes to stop. On a smooth surface, the scooter may slip, lose balance, and even result in a fall. Thus it is crucial that you use caution, keep proper speed and distance, especially so when you're unfamiliar with the place.
- Respect pedestrians' Right of Way. Try not to startle them while driving, especially children. When you ride from behind pedestrians, ring your bell to give them a heads-up and slow your scooter to pass from their left (applicable to countries where vehicles drive on the right). When you ride across pedestrians, keep to the right at a low speed. When you drive across pedestrians, keep the lowest speed or getting off the vehicle.
- Closely follow the safety instructions in the manual especially in China and countries that lack relevant laws and regulations regarding electric scooters. Xiaomi Communication Co., Ltd. shall not be liable for any financial losses, physical injuries, accidents, legal disputes and other interest conflicts resulted from actions that violate user instructions.
- Do not lend your scooter to whoever knows not the operations. And when you do lend it to your friends, please take the responsibility to ensure he/she knows the operation and wears the safety gear.
- Check the scooter before every use. When you note loosen parts, low battery alerts, flat tires, excessive wear, strange sounds, malfunctions and other abnormal conditions, stop riding immediately and call for professional support.

WARNING – Risk of Fire – No User Serviceable Parts.

AVERTISSEMENT - Risque d' incendie -Aucune des pièces ne peut être réparée par l' utilisateur.

7 Folding and Carrying

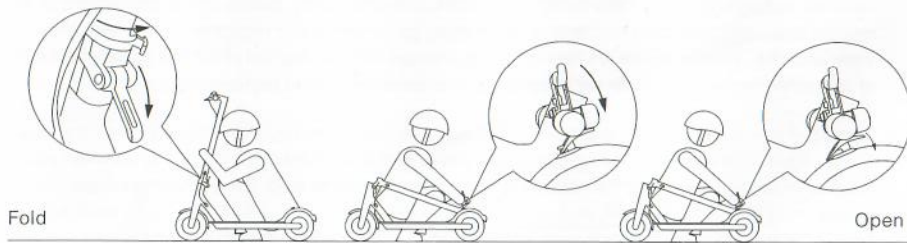

Make sure that the scooter's turned off. To fold, unlock the folding mechanism, and bend the handlebar stem to hook the buckle on the rear mudguard. To open, press the bell trigger to remove from the buckle, erect the handlebar and lock the folding structure.

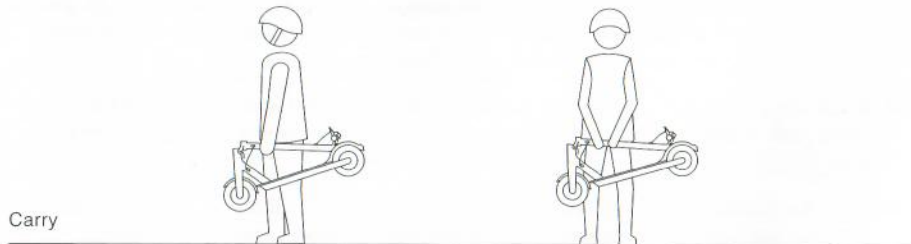

Hold the handlebar stem with either one hand or both hands to carry.

8 Daily Care and Maintenance

Cleaning and storage

If you see stains on the scooter's body, wipe them off with a damp cloth. If the stains won't scrub off, put on some toothpaste, and brush them with a toothbrush, then wipe them off with a damp cloth. If you see scratches on plastic parts, use sandpaper or other abrasive materials to polish them.

Notes: do not clean the scooter with alcohol, gasoline, kerosene or other corrosive and volatile chemical solvents to prevent dire damage. Do not wash the scooter with a high-pressure water spray. During cleaning, make sure that the scooter's turned off, the charging cable is unplugged, and the rubber flap is closed as water leakage may result in electric shock or other major problems.

When the scooter's not in use, keep it indoors where it is dry and cool. Do not put it outdoors for long time. Excessive sunlight, overheating and overcooling accelerate tire aging and compromise the scooter and the battery pack's lifespan. (Lorsque le scooter n'est pas utilisé, gardez-le à l'intérieur dans un endroit sec et frais. Ne le mettez pas en plein air pendant longtemps. La lumière du soleil excessive, la surchauffe et le sur-refroidissement accélèrent le vieillissement des pneus et compromettent le scooter et la durée de vie de la batterie.)

Battery maintenance

1. Use original battery packs, use of other models or brands may bring about safety issues;
2. Do not touch the contacts. Do not dismantle or puncture the casing. Keep the contacts away from metal objects to prevent short circuit which may result in battery damage or even injuries and deaths;
3. Use original power adapter to avoid potential damage or fire;
4. Mishandling of used batteries may do tremendous harm to the environment. To protect natural environment, please follow local regulations to properly dispose used batteries.
5. After every use, fully charge the battery to prolong its lifespan.

Do not place the battery in an environment where the ambient temperature is higher than 50°C or lower than -20°C (e.g., do not leave the scooter or the battery pack in a car under direct sunlight for an extended time). Do not throw the battery pack into fire as it may lead to battery failure, battery overheating, and even another fire. If the scooter is expected to be left idle for more than 30 days, please fully charge the battery and place it in a dry and cool place. Keep in mind to recharge it every 60 days to protect the battery from potential damage which is beyond limited warranty.

Always charge before exhausting the battery to prolong the battery's lifespan. The battery pack performs better at normal temperature, and poor when it is below 0°C. For instance, when it is below -20°C, the riding range is only half or less at normal state. When the temperature rises, the riding range restores. For detailed information, please refer to Mi Home App.

Note: fully charged Mi Electric Scooter will last for 120-180 days. The built-in intelligent chip will keep a log of its charging and discharging records. The damage caused by prolonged no charge is irreversible and is beyond limited warranty. Once the damage is done, the battery can not be recharged (non-professionals are forbidden to dismantle the battery pack, as it may cause electric shock, short circuit or even major safety accidents).

Adjusting the disc brake

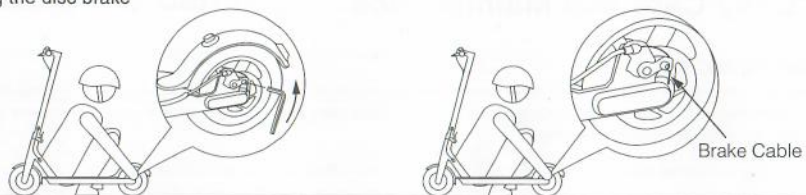

If the brake is too tight, use the M4 hexagon wrench to loosen the screws on the caliper, and slightly send back the brake cable to shorten the exposed length, then tighten the screws. If the brake is too loose, loosen the screws, and slightly pull out the brake cable to lengthen the exposed length, then tighten the screws.

Adjust the handlebar

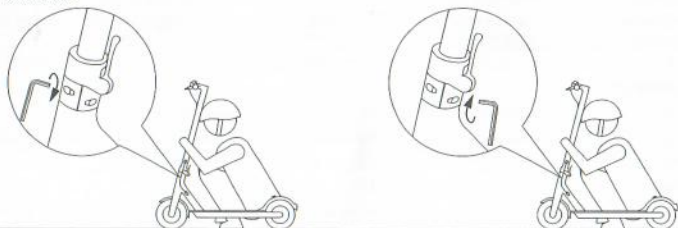

If the handlebar and its stem sway during riding, use the M5 hexagon wrench to tighten the screws on the folding mechanism.

How to use the extended nozzle adapter

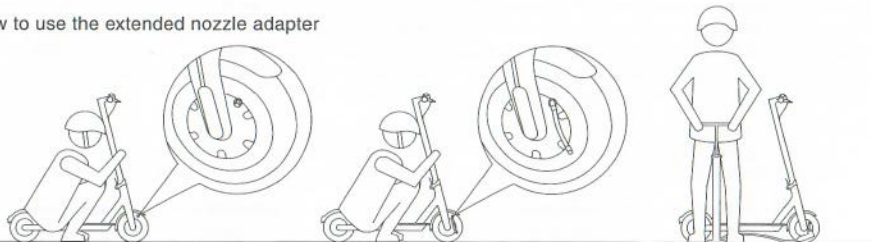

If your tires are flat, remove the screw-on cap from the valve, and connect the extended nozzle adapter to the valve for pumping up.

Remove the outer and inner tires

Note: Crowbars not included, and should be purchased separately.



1. Deflate the inner tire first. Use a tool to press the core rod in the air valve so that air is discharged from the inner tire, and use another hand to forcibly pinch the tire at different places to discharge more air.
2. Select a position far from the air valve on the outer tire, use two crowbars to prize up the outer tire by about 1/6 of the circumference, and forcibly separate one side of the outer tire from the hub.
3. Find the air valve, and pull the air valve out of the air valve hole of hub. To pull out the air valve more conveniently, hold the air valve of the inner tire, and pull the outer tire outwards slowly, lest the inner tire would be damaged. Remove the inner tire from the position of air valve in sequence, and separate the inner tire finally.

Note: Wrap the pointed end of the crowbar with fiber cloth so that it will not damage the inner tire and coating of the hub.

Install the inner and outer tires

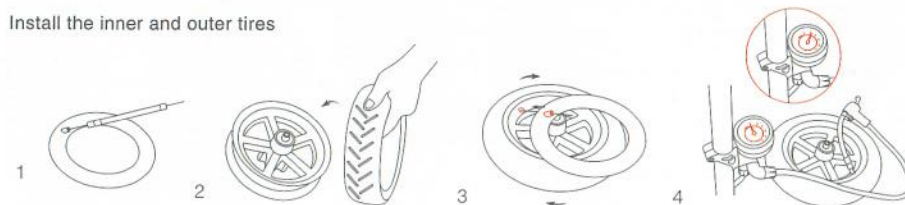

1. Fill a small amount of air into the deflated inner tire till the inner tire is just bulged to look round.
2. Put the hub on the top of a desk. Pay attention to the direction when installing the outer tire. There is an arrow on the outer tire, and it must be consistent with the forward direction of the wheel. Use one hand to hold the hub, and use the other hand to insert one side of the outer tire in the hub groove.
3. Insert the air valve of the inner tire into the air valve hole. Insert the inner tire in the outer tire clockwise and in sequence. Make sure that the air valve does not tilt. Then, insert the other side of the outer tire in the hub groove. Finally use a crowbar to install the remaining tire lips in the hub groove. After installation, pinch the outer tire to check if the inner tire is pressed by the tire lips of outer tire.
4. Inflate the inner tire to 15-20 PSI, and check the safety lines at two sides of the outer tire. Make sure that the distances from the safety lines to the hub edge are consistent.
5. Finally inflate the inner tire to 45-50 PSI. Tighten the air valve cap. Then, the tire assembly is completed.

Note: Wrap the pointed end of the crowbar with fiber cloth so that it will not damage the inner tire and coating of the hub.

9 Specifications

Performance index	Items	Specifications
Dimensions	L × W × H [1] (cm)	108×43×114
	After folding: L × W × H (cm)	108×43×49
Weight	Item weight (kg)	Approx. 12.2
Riding requirements	Load range (kg)	25-100
	Age	16-50
	Body length (cm)	120-200
Main parameters	Max. speed (km/h)	Approx. 25
	General range[2] (km)	Approx. 30
	Max. climbing angle (%)	Approx. 14
	Suitable surfaces	Cement, asphalt and mud roads; bench lower than 1cm; crevice narrower than 3cm
	Operating temperature (°C)	-10-40
	Storage temperature (°C)	-20-45
	IP rating	IP54
Battery pack	Rated voltage (VDC)	36
	Max. input voltage (VDC)	42
	Rated capacity (Wh)	280
	Intelligent battery management system	Unusual temperature/short circuit/under voltage/over current/dual overcharge/dual over-discharge protections
Wheel Motor	Rated power (W)	250
	Max. power (W)	500
Charging adapter	Output power (W)	71
	Input voltage (VAC)	100-240
	Output voltage (VDC)	42
	Output current (A)	1.7
	Charging time (h)	Approx. 5

[1] Item height: from the ground to the top of the scooter;

[2] General range: measured when it is no wind and at 25°C, the scooter's fully charged to ride at a even speed of 15 km/h on a flat surface with a load of 75 kg.

Note: data and specifications may vary due to different models, and are subject to change without notice.

10 Trademark and Legal statement

mi is a registered trademark owned by Xiaomi Inc (hereinafter referred to as Xiaomi). Xiaomi reserves all rights to the trademark **mi**. Ninebot is a registered trademark of Ninebot(Tianjin) Technology Co., Ltd., all other trademarks and trade names are those of their respective owners.

© 2017 Ninebot (Beijing) Technology Co., Ltd all rights reserved.

This manual included all functions and instructions when it is printed. But actual product may vary due to improved functions and design. Please scan the QR code in the back cover for latest user manual.

Principal: Xiaomi Communications Co., Ltd.

Manufacturer: Ninebot (Changzhou) Tech Co., Ltd.

Address: 16F-17F, Block A, Building 3, No.18, Changwu Mid Rd, Wujin Dist., Changzhou, Jiangsu, China.

11 Certifications

Federal Communications Commission (FCC) Compliance Statement for USA

This device complies with part 15 of the FCC rules. Operation is subject to the following two conditions: (1) This device may not cause harmful interference, and (2) this device must accept any interference received, including interference that may cause undesired operation.

Note: This equipment has been tested and found to comply with the limits for a Class B digital device, pursuant to part 15 of the FCC Rules. These limits are designed to provide reasonable protection against harmful interference in a residential installation. This equipment generates, uses and can radiate radio frequency energy and, if not installed and used in accordance with the instructions, may cause harmful interference to radio communications. However, there is no guarantee that interference will not occur in a particular installation. If this equipment does cause harmful interference to radio or television reception, which can be determined by turning the equipment off and on, the user is encouraged to try to correct the interference by one or more of the following measures:

- Reorient or relocate the receiving antenna.
- Increase the separation between the equipment and receiver.
- Connect the equipment into an outlet on a circuit different from that to which the receiver is connected.
- Consult the dealer or an experienced radio/TV technician for help.

This equipment complies with FCC radiation exposure limits set forth for an uncontrolled environment.

Industry Canada (IC) Compliance Statement for Canada

This device complies with Industry Canada license-exempt RSS standard(s). Operation is subject to the following two conditions: (1) this device may not cause interference, and (2) this device must accept any interference, including interference that may cause undesired operation of the device.

Le présent appareil est conforme aux CNR d'Industrie Canada applicables aux appareils radio exempts de licence. L'exploitation est autorisée aux deux conditions suivantes : (1) l'appareil ne doit pas produire de brouillage, et (2) l'utilisateur de l'appareil doit accepter tout brouillage radioélectrique subi, même si le brouillage est susceptible d'en compromettre le fonctionnement.

CAN ICES-3 (B)/NMB-3(B)

Ninebot is not responsible for any changes or modifications not expressly approved by Ninebot. Such modifications could void the user's authority to operate the equipment.

For model: M365
FCC ID: 2ALS8-NS9633
IC : 22636-NS9633

European Union Compliance Statement Battery recycling information for the European Union



Batteries or packaging for batteries are labeled in accordance with European Directive 2006/66/EC concerning batteries and accumulators and waste batteries and accumulators. The Directive determines the framework for the return and recycling of used batteries and accumulators as applicable throughout the European Union. This label is applied to various batteries to indicate that the battery is not to be thrown away, but rather reclaimed upon end of life per this Directive.

In accordance with the European Directive 2006/66/EC, batteries and accumulators are labeled to indicate that they are to be collected separately and recycled at end of life. The label on the battery may also include a chemical symbol for the metal concerned in the battery (Pb for lead, Hg for mercury, and Cd for cadmium). Users of batteries and accumulators must not dispose of batteries and accumulators as unsorted municipal waste, but use the collection framework available to customers for the return, recycling, and treatment of batteries and accumulators. Customer participation is important to minimize any potential effects of batteries and accumulators on the environment and human health due to the potential presence of hazardous substances.

Restriction of Hazardous Substances Directive (RoHS)

Ninebot (Changzhou) Tech Co., Ltd. products sold in the European Union, on or after 3 January 2013 meet the requirements of Directive 2011/65/EU on the restriction of the use of certain hazardous substances in electrical and electronic equipment ("RoHS recast" or "RoHS 2").

Radio and Telecommunications Terminal Equipment Directive



Hereby, Ninebot (Changzhou) Tech Co., Ltd. declares that the wireless equipment listed in this section are in compliance with the essential requirements and other relevant provisions of Directive 2014/53/EU.

12 Quick Setup

Control your Mi Electric Scooter and interacts it with other smart home devices in Mi Home App.

1. Download Mi Home App

Scan the QR code below or go to App Store to download Mi Home App



2. Add a device

Open "My devices", select "+" on the upper right to add a device

Legal Statement of Electric Scooter



www.mi.com

V1.1

Thank you for choosing our electric scooter. This electric scooter is a leisure device. In public areas, it is considered a means of transport with the same risks that other types of transport have. To reduce risks such as loss of control, collisions, and falls, you must learn how to ride the electric scooter and strictly abide by the local related laws and regulations. Xiaomi Inc. hopes that you enjoy a safe riding experience.

Think about how you learned to ride a bicycle or drive a car. Maybe someone helped in a safe environment – the same approach is needed for the electric scooter.

Before use, carefully read the Electric Scooter User Manual and Electric Scooter Legal Statement, and use the Mi Home App to find out more about safe riding.

Like with other transport modes, the rider of the electric scooter can get hurt. The warnings and precautions stipulated in the Electric Scooter User Manual decrease but cannot eliminate the risks. Please carefully read them and the following statements:

I. Personal Information Statement

1. Scope of personal information

You agree that we may collect the following personal information when you register in the Mi Home App (the App): name, gender, age, date of birth, ID number, address, contact information, hobbies, occupation, emergency contact, account information, and the time and location information of your usage of our service. You are providing the above information on a voluntary basis.

2. Collection and processing of personal information

The ultimate purpose for us to collect your personal information through the App is to provide you with better products and services and to improve and optimize your user experience. The specific collection methods and channels include, but not limited to:

- (1) Membership registration;
- (2) Questionnaire;
- (3) After-sales tracking and return visits;
- (4) Soliciting of comments or suggestions on products or services;
- (5) Organization of events and soliciting of participants.

You have the right to refuse to provide your personal information. However, if you refuse to provide certain personal information, you may not be able to use the products and services provided by us, or your use of such products or services may be affected.

3. Use and disclosure of personal information

- (1) You agree that your personal information may be used and disclosed (including being stored and processed) in the following ways: used by us (including our branches); disclosed by us to our affiliated

companies for their use; disclosed by us and our affiliated companies, within their respective normal business scopes, to and used by their respective assignees or successors, legal and financial advisers, external suppliers, and agents.

- (2) We and our affiliated companies may send you information about products, services, and activities. You agree to receive the aforesaid information.
- (3) We may disclose your personal information to a third-party other than those mentioned above under any of the following circumstances or for any of the following purposes:
 - upon your special authorization;
 - for compliance with mandatory requirements of laws or government authorities (including judicial authorities);
 - for performance of applicable service clauses (including investigations of possible violations);
 - for identifying, preventing, or handling issues relating to fraud, security, or technology;
 - to the extent required or permitted by the law, to protect the rights, interests, property, or safety of users or the public against damage; or
 - disclosed to and used by your emergency contact in an emergency.
- (4) The personal information may be transferred and stored by electrical means. The recipients and/or users of the aforesaid information and their servers may be located within or outside China.
- (5) We will protect the security of your personal information. We will adopt security technologies and procedures and other measures to protect your personal information against unauthorized access, use, or leaks. We will also cause the recipients and users stated herein to undertake to protect and keep confidential your personal information.
- (6) You agree to exempt the recipients stated herein and/or users of the personal information from all claims, liabilities, or losses that arise or may arise with respect to information disclosure and use according to the clauses herein, unless such claims, liabilities or losses are directly caused by willful misconduct or gross negligence of the recipients and/or users.

(7) We will keep your personal information for a period not longer than the period necessary for the intended purpose of collecting such information, or the period specified in any contract or applicable law.

(8) For details about collection, storage and use of user data, see the privacy policy of Xiaomi Inc. at www.miui.com/res/doc/privacy/cn.html.

II. Copyright Statement

We reserve all rights associated with the All texts, images, photos, audios, animations, videos, layout designs, and other intellectual properties are under legal protection. They may not be reproduced for commercial use or distribution, or be used on other sites or apps after modification.

III. Trademark Statement

 is the registered trademark of Xiaomi Technology Co., Ltd. (hereinafter referred to as Xiaomi). Xiaomi Inc. reserves all rights to the trademark. Other trademarks mentioned herein may be registered trademarks of their respective owners.

IV. Product Statement

Familiarity with the electric scooter makes riding easier. So, please kindly note that:

1. Read the Electric Scooter User Manual carefully before riding the vehicle.

2. Do not allow anyone who has not read the Electric Scooter User Manual to use your electric scooter.
3. Correctly install all parts as instructed in Electric Scooter User Manual. Improper installation may lead to loss of control, collisions, and falls. Turn off the power before installation and maintenance. Tighten all parts properly. If the parts are too loose or too tight, it may cause vehicle damage or malfunction.
4. Do not charge the product when the socket is wet. To charge the product, insert the power cable into a correct socket (200-240 V/50-60 Hz), and keep it away from children, pets, and flammable materials.
5. Do not place the battery in an environment where the ambient temperature is higher than 50°C (122°F) or lower than -20°C (-4°F).
6. Do not use the battery if it is damaged, has a strange odor, emits smoke, or gets overheated. Keep a leaking battery away from other objects.
7. Do not try to open or dismantle the batteries, because they contain hazardous materials inside.
8. Recharge the electric scooter in time to avoid damaging the battery. A fully-charged electric scooter can remain on in standby mode for about 120 to 180 days while an undercharged electric scooter can remain on in standby mode for about 30 to 60 days.
9. Familiarize yourself with the electric scooter before riding outdoors. The more you practice, the safer you will be when riding in a new environment. Remember the following essentials: Start with the basic exercises like going forward, turning, stopping in open places without barriers ($\geq 10 \text{ m} \times 10 \text{ m}$, or 32.8 ft x 32.8 ft), and keeping your body relaxed. It is advisable for you to practice for the first time under instructions of an experienced user or a coach. When you have mastered the basic skills, practice riding through narrow areas, and then turning and stopping. After you can precisely control the vehicle in narrow spaces and on various surfaces, you can start to ride on roads. If your electric scooter is updated, start again with the basics.
10. Examine the electric scooter every time before you ride it. Ensure that there are no loose or damaged parts.
11. Look around before and during riding and braking to avoid injury, damaging the surrounding environment, or injuring others.

12. Ensure that the tire pressure is within the range specified in the parameter table. Overly high pressure will raise the risk of loss of control, collisions, and falls. Too low pressure will damage the tire.
13. Check the tire pressure at least twice a month or every time you ride long distance to avoid instability, accidents, and tire damage.
14. If the tire becomes loose, stop riding immediately and check the tire.
15. Step on the electric scooter from either sides and wear professional protective gear.
16. Do not wear high-heeled shoes when riding the electric scooter.
17. Do not immerse the battery or vehicle in water. Avoid heavy or lengthy exposure to rain and do not clean the vehicle with high pressure water as water may get into the charging port. If your electric scooter has already been exposed to rain, use a soft, dry cloth to wipe it down. Stop using the vehicle immediately and contact the after-sales service. Do not perform other operations except wiping the body, because improper care and cleaning will void the warranty.
18. Braking performance and friction between the tire and road deteriorates in wet conditions, so it is harder to control the speed and easier to lose control. Slow down and brake early when it is raining.
19. Recharge the battery when the low-battery icon is displayed because the electric scooter may not have adequate power to maintain a high-speed riding.
20. Keep vigilant at all times even if it is easy for you to ride the electric scooter. Do not go over obstacles or ride on rugged or wet roads, loose surfaces, or slopes.
21. Watch out for surface changes on roads and grass.
22. Be careful when turning and do not turn too fast.
23. Do not take the risk of riding on steep slopes, rugged surfaces or other surfaces that you did not encounter before.
24. Do not ride on motorways. Obey the traffic rules, let pedestrians go first, and never run a red light.
25. Respect the rights of motorcycle drivers, cyclists, pedestrians and other people.
26. Take precautions during riding and be aware of your safety, traffic and pedestrians.
27. Be prepared to respond to any of these dangers: vehicles decelerating or turning in front of or behind you; opening car doors; people crossing the road; children and pets near the road; and distractions like

potholes, manhole covers, rail lines, construction, debris, and so on.

28. Ride on designated cycle tracks or the road edge if possible. Go in a direction allowed by traffic regulations or that specified by local government and laws.
29. Stop when you see a stop sign or at traffic lights. Get off slowly and watch the traffic. Please keep in mind that there is a risk of colliding with other vehicles when you are riding the electric scooter. Allow automobiles to go first even when you are riding on your dedicated path.
30. Do not seek thrills by holding onto other vehicles to get pulled along.
31. Do not perform stunts when you are riding.
32. Do not ride in bad weather, low visibility, or after intense physical exertion.
33. Do not ride alone in remote areas. Even when you are accompanied by someone else, ensure that people know your destination and the time you expect to return.
34. Be aware of the height added by your helmet and by standing on your electric scooter. Be careful when you ride indoors, through doorways, or in other low-height places.
35. Do not wear loose clothing that might get trapped in the wheel.
36. Wear protective eyewear when riding to protect your eyes against dirt, dust, and insects. Use darker lenses when it is bright and clearer lenses when it is dim.
37. Do not carry passengers or children.
38. The electric scooter is not a medical instrument. Do not ride the electric scooter if you cannot get on or off the vehicle without assistance.
39. Do not ride the electric scooter on stairs, in elevators, or through revolving doors.
40. Do not ride the electric scooter in low visibility conditions.
41. Do not ride the electric scooter on highways unless it is allowed by law.
42. Do not use the electric scooter to transport cargo.
43. Slow down and give way to pedestrians, bicycles, and automobiles when approaching or passing through

crossroads, motorways, corners, and gates.

44. Remain vigilant when you ride the electric scooter as you do with another means of transport. Do not ride the electric scooter when you are ill or under the influence of alcohol or drugs.
45. Do not use your phone or perform other tasks when riding because you need to be aware of your surroundings all the time.
46. Note that the electric scooter is designed for people between the ages of 16-50. Parents are advised not to allow their minor children to ride the electric scooter.
47. Do not make emergency stops, especially on smooth surfaces, to avoid skidding and falling.
48. The vehicle may slide if it is parked and powered on, so turn the power off when you park.
49. In summer, store the electric scooter in a safe place where the temperature is below 45°C (133°F). Do not leave it under direct sunlight for an extended time.
50. In winter, store the vehicle in a safe place where the temperature is not lower than -20°C (-4°F). After storing the vehicle in sub-zero temperatures, move it to and place it in a place with room temperature for at least half an hour before charging it.
51. Do not modify the electric scooter.
52. Know and comply with the law in the place you ride the electric scooter.
53. Aim to avoid non-standard components for replacement, even when they are approved by certain official sectors, because we cannot guarantee they are safe. Contact our after-sales support department if you are in doubt.
54. The data and parameters of the electric scooter vary with models, and are subject to change without notice.

This statement is governed by the laws of the People's Republic of China.

We shall not be liable to any customer for any claims, responsibilities or losses arising from or as a consequence of the customer's violation of the preceding provisions. Riders shall be responsible for any unforeseen or unavoidable risks during riding. You may choose to accept the preceding provisions and start to use the product, or not to accept the preceding provisions and return the product. You must keep the returned product and its package in a condition that does not affect resale of the product.

To resell your electric scooter, remember to hand this Legal Statement together to the buyer, because it is a statutory part of the vehicle.

If you have any questions, please feel free to contact us.

Thank you again for choosing our products.